

FS400 / SR300 Footswitch Assembly

FS400 Footswitch Assembly for Shuttle Cars, Haulers, Scoops and other mine utility vehicles

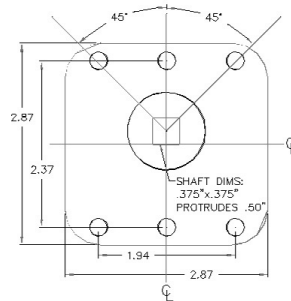

SR300 Drop in replacement for Sevcon Footswitch

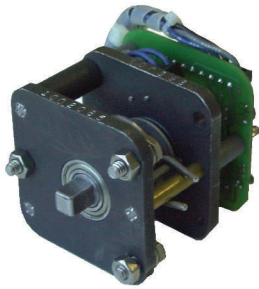
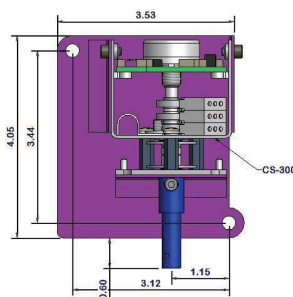
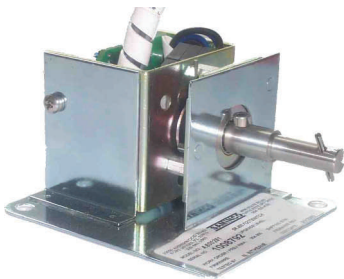

Block Diagram

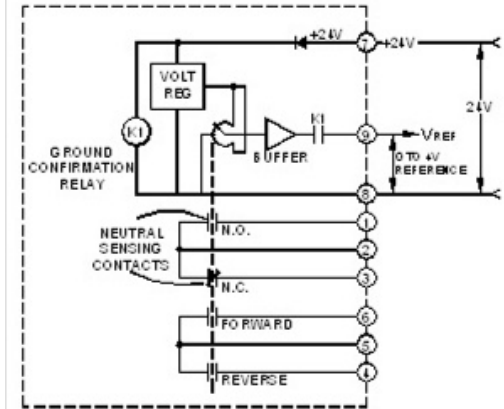

Electronic Tram Reference with built in safety features

- Rugged footswitch assembly for off-road electric vehicles
- Configured for symmetrical forward / reverse operation
- Mounts inside commonly -available explosion-proof housings used for shuttle cars, continuous miners, scoops and battery haulers
- Incorporates improved safety features:
 - Neutral sensing contact
 - Missing ground/common wire protection
- Gearless construction allows full 0 to 4V output variation for 0 to 45° foot pedal movement from either direction
- Buffered, low impedance output allows use with many different solid-state controllers
- DC supply input reverse polarity protected. Misconnection to other terminals will not damage footswitch circuit.

SAMINCO Part Number: FS-400 A800498

SR-300 A800281

SPECIFICATIONS:

Input Supply: 20VDC to 30VDC @ 20mA

Output : 0 to 4VDC = 0—100% Reference

Neutral: N.O. (normally open) and N.C. (normally closed) contacts at "0" position rated 1A @ 30VDC

Forward/Reverse: N.O. contact for Reverse; N.O. contact for Forward (Each rated 1A @ 30VDC)