

Diagnostic Display / Interface Box For A750 Plus

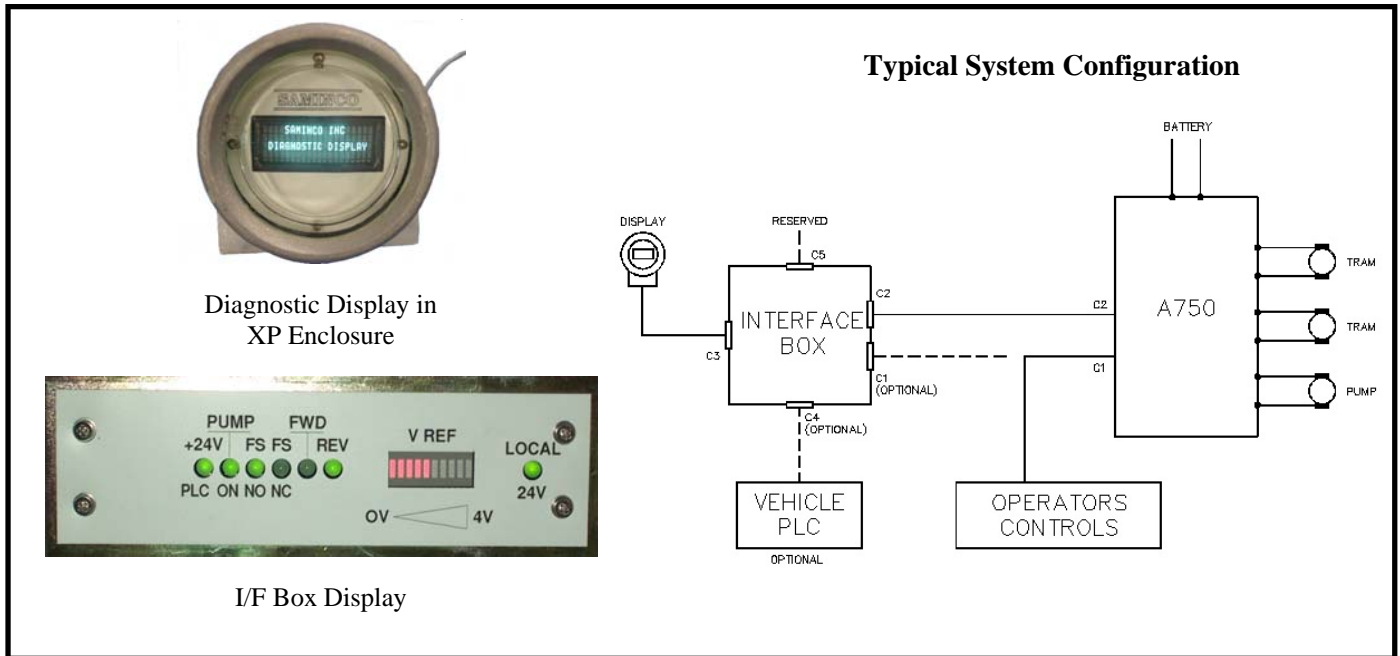

- Interface Box and Digital Display for Saminco A750 Series Battery Traction and Pump Controllers
- Convenient diagnostic indicators on Interface Box:
 - Internal Supply Present
 - Pump "on"
 - Direction Selected
 - Linear Bar Graph indicating Tram Reference Voltage
- Comprehensive 4 line, easy to read Vacuum Florescent Display in MSHA approved XP Housing:
 - Controller Heatsink Temperature
 - Motor Current (Tram A and Tram B)
 - Warning and Fault Messages
 - Battery State of Charge Indication (optional), Motor Speed or Motor Temperature (optional)

SAMINCO Part Number: Please consult Factory, Part Number is dependent upon Options Selected

SPECIFICATIONS:

<p><u>Interface Box</u> 7" x 8" x 3" self contained unit Microprocessor controlled functions Visual Critical Drive Status Indicators</p> <p>Options: Vehicle PLC Interface Battery State of Charge Gauge Motor Speed or Temperature Protection</p>	<p><u>Diagnostic Display</u> Bright, Easy to read Vacuum Florescent Display Real time display of Motor Current Understandable Warning and Fault Messages Mounted in standard XP Headlight Housing (optional chassis mount available)</p>
---	---